

▲ 产品规格 Specifications

缸径(mm) Bore	16	20	25	32	40	50	63
动作型式 Action Type	双动型 Double action						
工作介质 Working Fluid	空气 Air						
固定型式 Mounting Type	基本型 LB型 FA型 SDB型 Basis style LB type FA type SDB type					基本型 Basis style	
工作压力MPa Working Pressure range	0.1—0.9						
耐压MPa Proof pressure	1.35						
工作温度℃ Working temperature	0 ~ 60℃						
工作速度mm / s Working speed	50 ~ 800					30 ~ 500	
缓冲型式 Cushion type	标准型Standard	缓冲垫片Rubber cushion					
	缓冲型Cushion	-	可调式缓冲Adjustable cushion				
接管口径 Port	M5x0.8		PT1 / 8			PT1 / 4	



图形符号 Symbol



▲ 订购码 Order Code

MA-U-32X100-LB

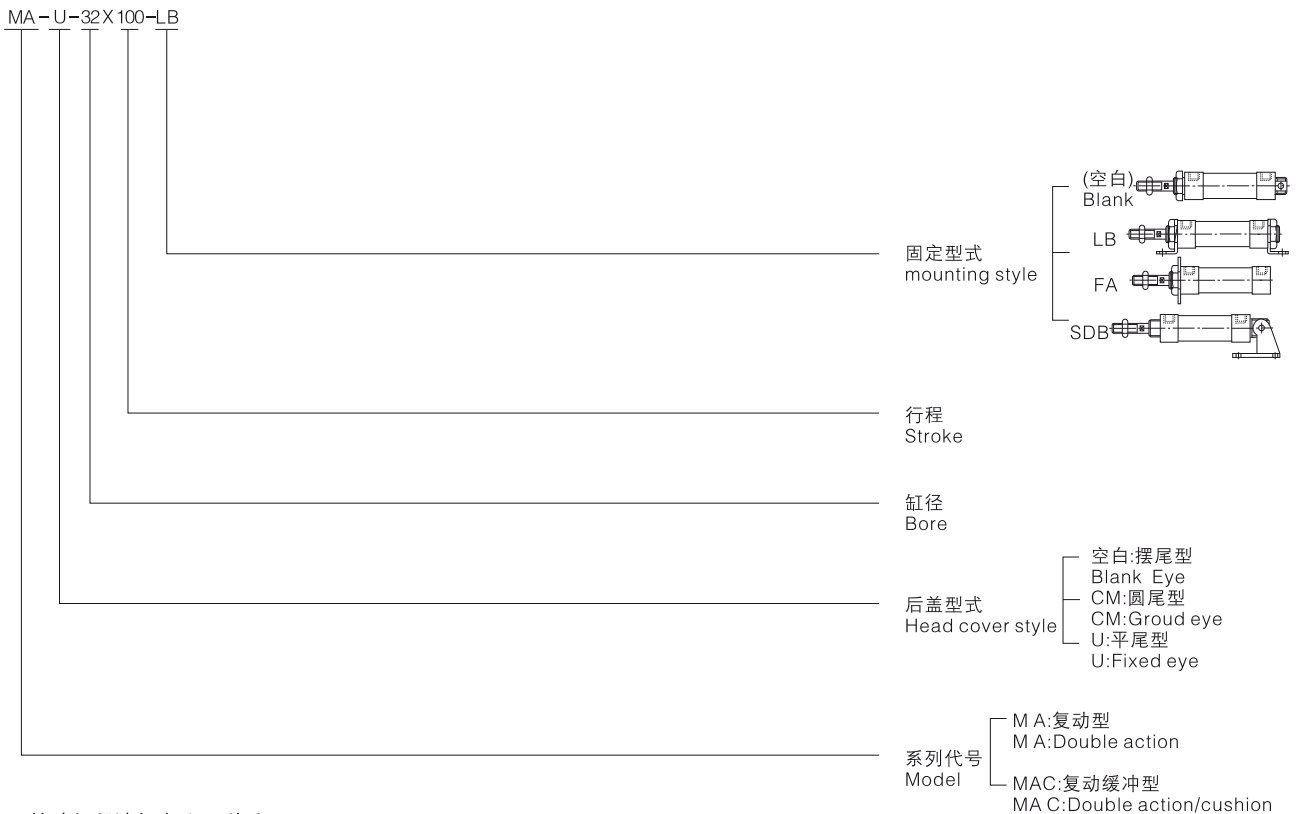

※特殊行程请与本公司联系
※Special stroke contact us

MA、MAC系列

Series

▲ 内部结构 Internal Structure

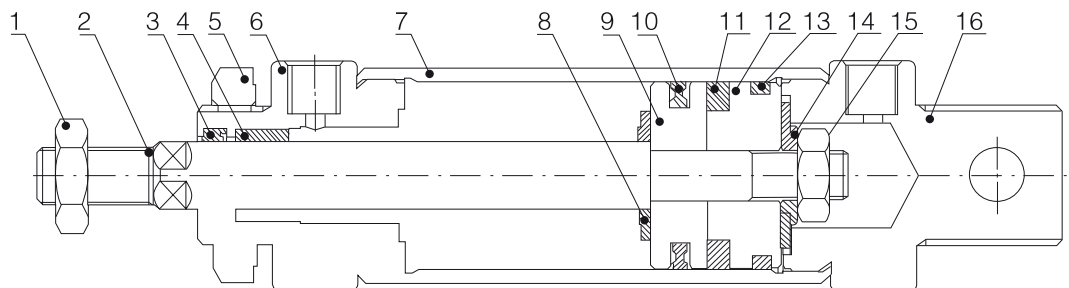

序号No.	名称	Part name	序号No.	名称	Part name
1	螺母	Nut	9	活塞	Piston
2	活塞杆	Piston rod	10	活塞O形圈	Piston seal
3	前盖密封圈	Rod packing	11	磁铁	Piston magnet
4	含油轴承	Bush	12	磁铁座	Magnet mount
5	前盖螺母	Nut	13	耐磨环	Wear ring
6	前盖	Rod cover	14	弹垫	Washer
7	不锈钢管	Cylinder tube	15	外六角螺母	Hexagon nut
8	防撞垫片	Cushion rubblej	16	后盖	Head cover

缸径(mm)	Bore	16	20	25	32	40	50	63
缸筒	Cylinder	不锈钢		Stainless steel				
活塞	Piston	铝合金		Aluminum alloy				
活塞杆	Piston Rod	高碳钢(镀硬铬研磨处理)		High carbon steel(Industrial chrome plated)				
活塞O形圈	Piston seal	NBR						
前盖密封圈	Rod packing	NBR						
含油轴承	Bush	含油粉末冶铜		Oil impregnated bearing alloy				
前盖	Rod cover	铝合金		Aluminum alloy				
后盖	Head cover	铝合金		Aluminum alloy				
磁铁	Magnet	塑胶		Plastic magnet				
缓冲垫片	Cushion rubblej	NBR						

B

HYC
HYCD
HYCJ
HYCT
HYC
MBB
QGA(B)
CA1
CS1
DNC
SDA
SDAD
SDAJ
SDAT
SDAW
SDA
CQS
CQ2
ADVU
MAL
MSAL
MALD
MALJ
MAL
MA MAC
MSA
MAD
MAJ
MAR
MA
CJ2
CM2
DSNU
CU
TN
CXS
CXSW
MGP
CJP
CY1B(S)
MH
ZH

▲ 外形尺寸(毫米) Overall Dimension(mm)

φ16~φ40
摆尾型 Eye

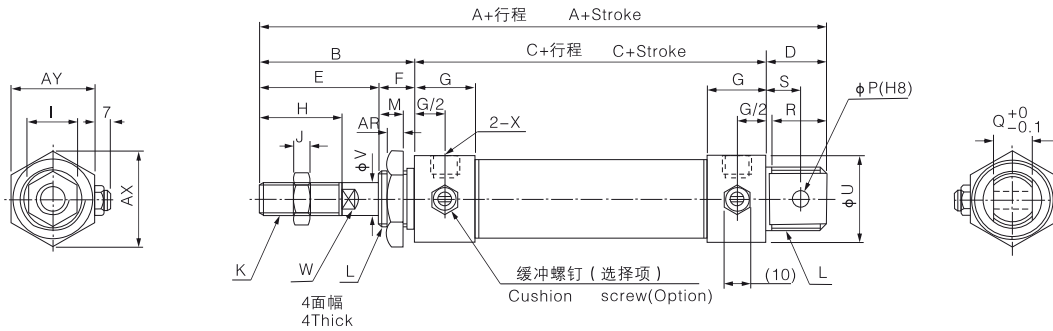

平尾型 Fixed eye

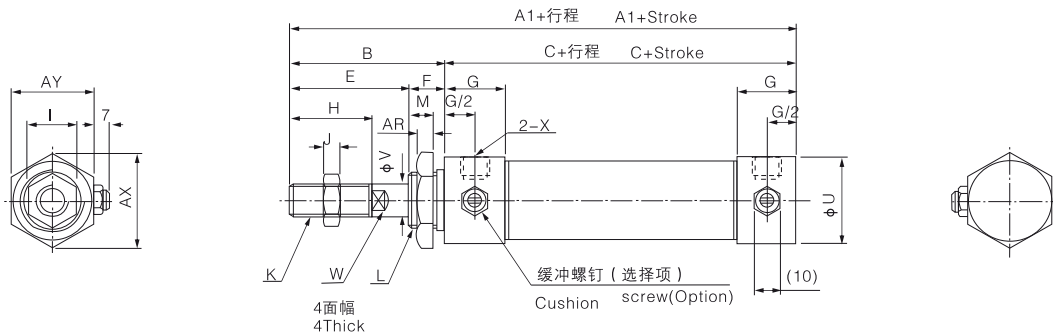

缸径 Bore	A	A1	B	C	D	E	F	G	H	I	J	K
16	114	98	37	60	16	22	16	10	16	10	5	M6x1
20	137	116	40	76	21	28	12	16	20	12	6	M8x1.25
25	141	120	44	76	21	30	14	16	22	17	6	M10x1.25
32	147	120	44	76	27	30	14	16	22	17	6	M10x1.25
40	149	122	46	76	27	32	14	16.7	24	17	7	M12x1.25

缸径 Bore	L	M	P	Q	R	S	U	V	W	X	AR	AX	AY
16	M16x1.5	14	6	12	14	9	21	6	5	M5x0.8	6	25	22
20	M22x1.5	10	8	16	19	12	27	8	6	PT1/8	7	33	29
25	M22x1.5	12	8	16	19	12	30	10	8	PT1/8	7	33	29
32	M24x2.0	12	10	16	25	15	35	12	10	PT1/8	8	37	32
40	M30x2.0	12	12	20	25	15	41.6	16	14	PT1/8	9	47	41

MA、MAC系列 Series

▲外形尺寸(毫米) Overall Dimension(mm)

φ50~φ63

摆尾型 Eye

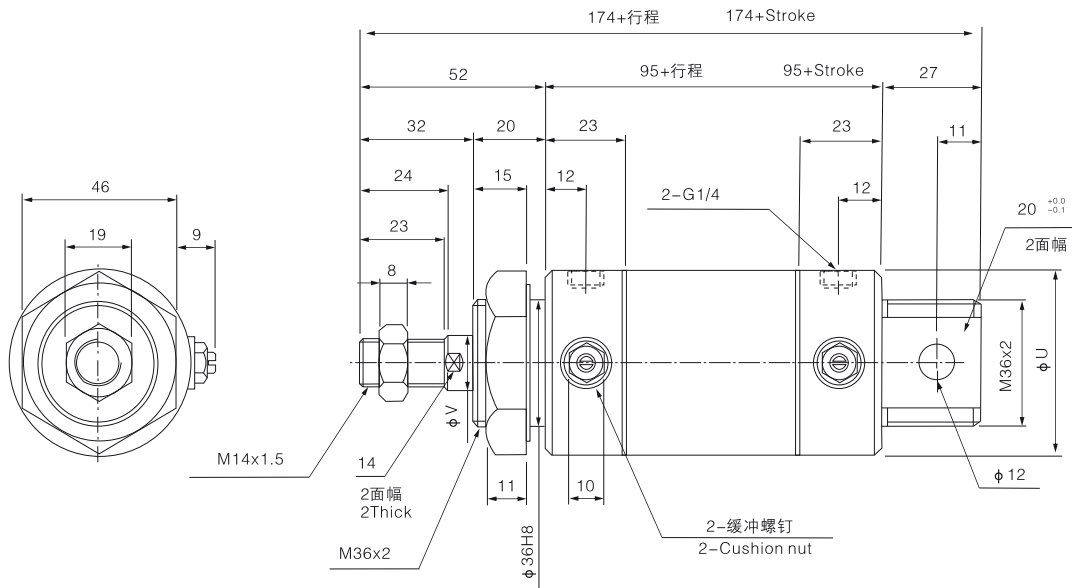

平尾型 Fixed eye

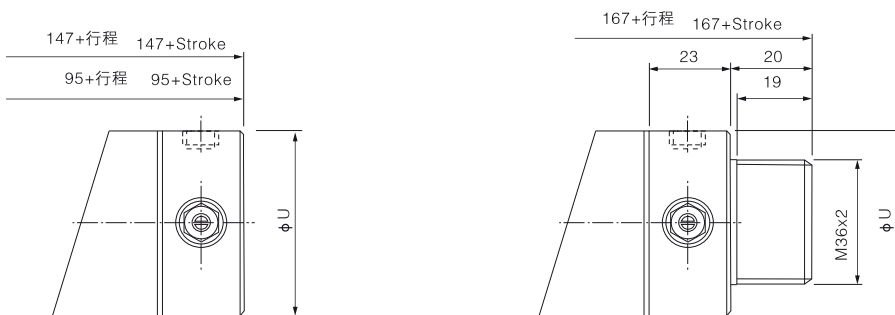

缸径/符号Bore/Sign	U	V
50	53	16
63	67	16

B

- HYC
- HYCD
- HYCJ
- HYCT
- HYC
- MBB
- QGA(B)
- CA1
- CS1
- DNC
- SDA
- SDAD
- SDAJ
- SDAT
- SDAW
- SDA
- CQS
- CQ2
- ADVU
- MAL
- MSAL
- MALD
- MALJ
- MAL
- MA MAC**
- MSA
- MAD
- MAJ
- MAR
- MA
- CJ2
- CM2
- DSNU
- CU
- TN
- CXS
- CXSW
- MGP
- CJP
- CY1B(S)
- MH
- ZH